

SALES DRAWING

SALES DRAWING

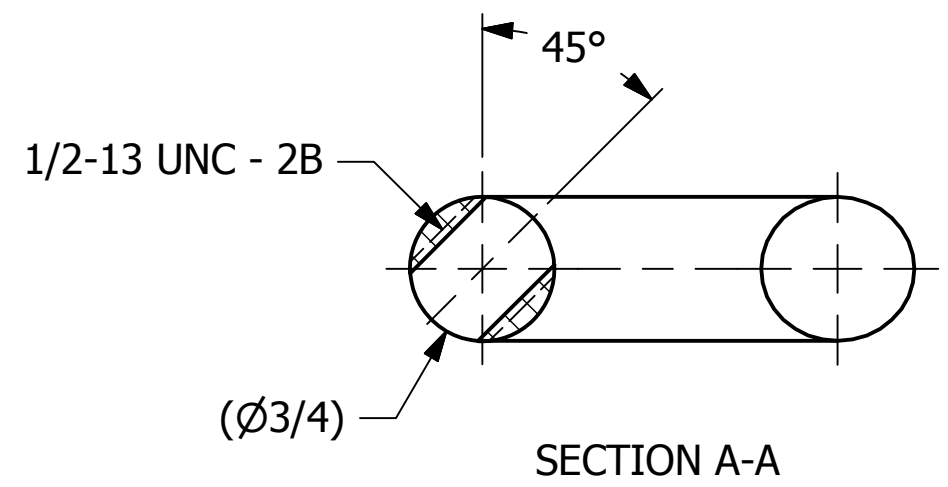
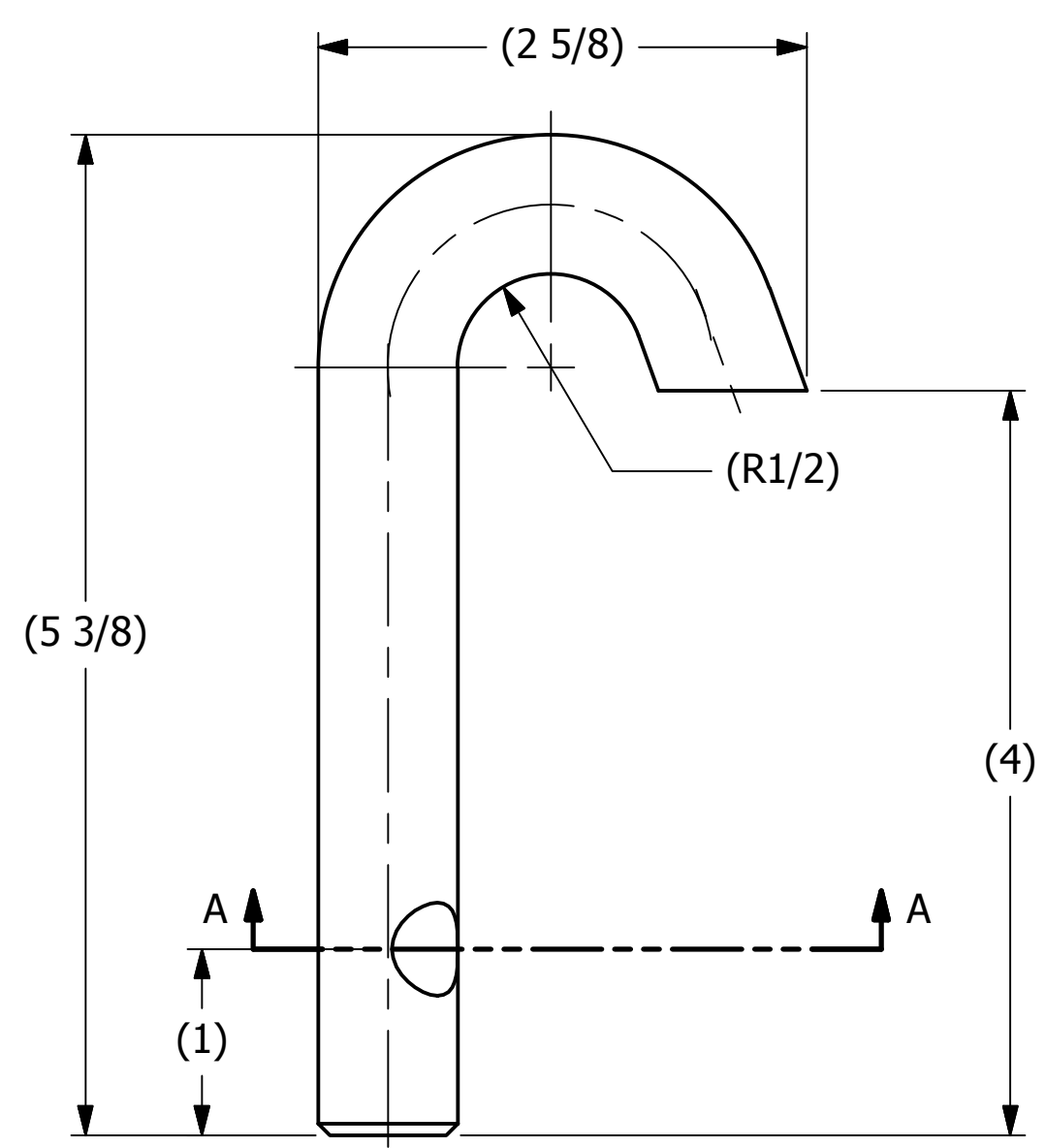

THIS PRINT, PROPERTY OF SALCO PRODUCTS INC., CONTAINS PROPRIETARY INFORMATION AND MUST NOT BE COPIED, REPRODUCED, OR USED DETRIMENTALLY TO OUR INTEREST.

REV	BY	DATE	DESCRIPTION
D	WEB	1-25-17	MADE INDIVIDUAL DRAWING SEPERATE FROM CHART
C	TJN	5-13-91	CHANGED PLATING TO ZINC & CLEAR
B	FRS	1-30-91	REERSED PART NO.
A	DKP	7-2-90	NICKEL PLATING WAS ZINC

UNLESS OTHERWISE SPECIFIED DIMENSIONAL TOLERANCES		DRAWN BY:	DKP
FRACTIONAL:	±1/16	CHECKED BY:	
X.XX:	±.03	PROTOTYPE BY:	DKP
X.XXX:	±.015	PROTOTYPE DATE:	4/11/1990
ANGULAR:	±1°	APPROVED FOR PRODUCTION BY:	
DEBURR ALL SHARP EDGES. ALL MACHINED SURFACES TO HAVE A 125 RMS FINISH UNLESS NOTED OTHERWISE.		PRODUCTION DATE:	4/11/1990
THIRD ANGLE PROJECTION			

PART NAME: <b>RIGHT HAND J BOLT</b>		
MATERIAL: <b>ZINC-PLATED CARBON STEEL</b>		
PROJECT #:	SHEET #: <b>1 OF 1</b>	SCALE: <b>1:1</b>
DRAWING #: <b>B41190B</b>	PART #: <b>EA205RJ</b>	